

D100x140 S3 NAVIGATOR[®]

HORIZONTAL DIRECTIONAL DRILL



OPEN-TOP VISE. An angled, open-top vise allows for the passage of larger tooling. Because of the large opening, operators can also use it to break out tooling.



STACKABLE ROD BOXES. Stackable rod boxes are easy to use with a single pin and patent-pending auto lock.



DRILL EFFICIENTLY. The D100x140 S3 features the DigiTrak[®] Aurora[™] full-color touchscreen display, delivering an engaging experience, which helps make a driller's day more productive.



OPTIONAL ONBOARD CRANE. Choose the optional onboard knuckleboom style crane to reduce the amount of support equipment needed onsite.



INCREASE YOUR RANGE. Unique four-bar linkage rack and additional pads allow operators to set up entry angles of 11°–24° — increasing range attainable with tracks fully on ground.



FIRESTICK[®] DRILL ROD. Experience the difference that has made one-piece, forged Firestick drill rod the industry benchmark.

D100x140 S3 NAVIGATOR® HORIZONTAL DIRECTIONAL DRILL

GENERAL WEIGHTS AND DIMENSIONS

Minimum transport length (15 ft [4.6 m] rod option): 31.4 ft (9.5 m)

Minimum transport length (20 ft [6.1 m] rod option): 36.28 ft (11 m)

Minimum transport width: 102 in (254 cm)

Maximum transport height: 11.7 ft (3.56 m)

Minimum weight (15 ft [4.6 m] rod option): 50,300 lb (22,815.7 kg)

Minimum weight (20 ft [6.1 m] rod option): 52,500 lb (23,813.6 kg)

ENGINE

Make/Model: Caterpillar

Fuel type: Ultra-low sulfur diesel

Maximum engine rpm: 2,200 rpm

Gross horsepower: 275 hp (205 kW)

Emissions rating: Tier 4 Final (EU Stage V)

OPERATIONAL

Thrust/Pullback: 100,000 lb (444.8 kN)

Maximum carriage speed: 200 fpm (61 m/min)

Maximum spindle torque (low at maximum engine rpm):
14,000 ft-lb (18,981.5 Nm)

Maximum spindle speed: 210 rpm

Maximum ground drive speed: 3 mph (4.8 km/h)

Noise level at operator's ear: 82 dB(A)

DRILLING FLUID OPTION ONE (APLEX)

Maximum flow: 230 gpm (1,045.6 L/min)

Maximum pressure: 1,000 psi (6.9 MPa)

DRILLING FLUID OPTION TWO (KERR)

Maximum flow: 200 gpm (909.2 L/min)

Maximum pressure: 1,100 psi (7.6 MPa)

TRANSPORT DIMENSIONS

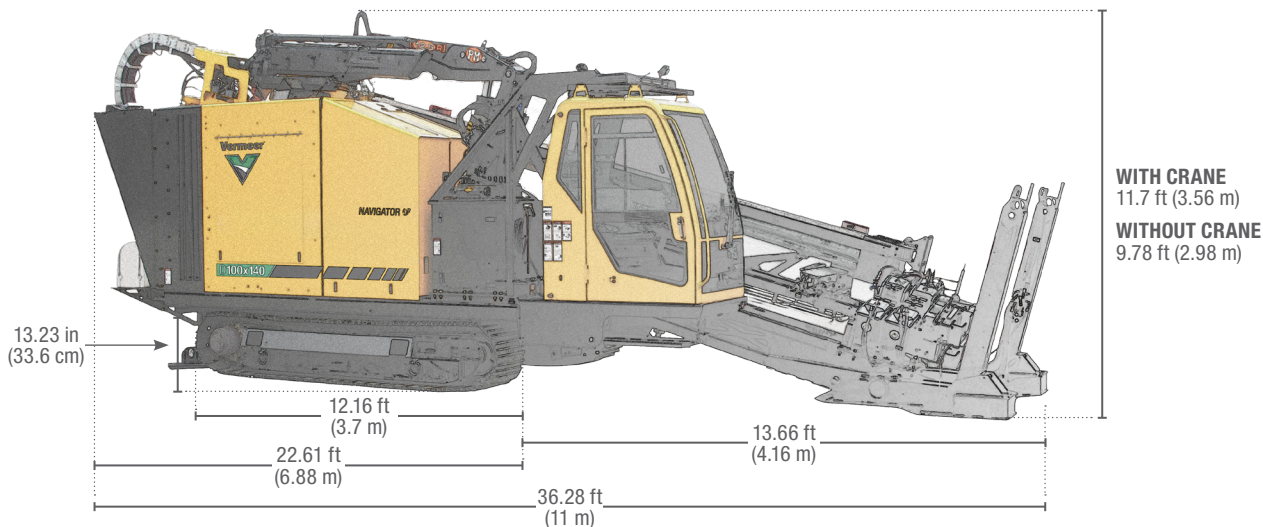

OPTIONAL CRANE

Weight: 2,600 lb (1,179.3 kg)

Maximum lifting capacity at 13 ft (3.95 m): 5,070 lb (2,300 kg)

Maximum lifting capacity at 19.5 ft (5.95 m): 3,970 lb (1,800 kg)

Rotation: 360°

Maximum reach: 19.5 ft (5.95 m)

DRILL PIPE OPTION ONE

Type: Firestick drill rod

Length: 15 ft (4.6 m)

Joint diameter: 4.375 in (11.1 cm)

Pipe diameter: 3.5 in (8.9 cm)

Weight: 261 lb (118.4 kg)

Minimum bend radius: 197 ft (60 m)

Rod carrying capacity: 135 ft (41.1 m) with permanent rod box,
270 ft (82.3 m) with stacked box

DRILL PIPE OPTION TWO

Type: Firestick drill rod

Length: 20 ft (6.1 m)

Joint diameter: 4.375 in (11.2 cm)

Pipe diameter: 3.5 in (8.9 cm)

Weight: 351 lb (159.2 kg)

Minimum bend radius: 197 ft (60 m)

Rod carrying capacity: 180 ft (54.9 m) with permanent rod box,
360 ft (109.7 m) with stacked box

OPTIONAL STAKE DOWN

Spade Stakedown

Aggressive Rotary Stakedown

Weight: 1,000 lb (454 kg)